

Multimode Filter Wavelength Division Multiplexer

Features

Low Insertion Loss
High Return Loss
High Environmental Stability

Applications

WDM Networks
Local Area Networks
Research

Specifications

Parameters		Unit	Values
Pass Band	Wavelength Range	nm	830-870(1290-1330) 1270-1350(1530-1600)
	Typ. Insertion Loss	dB	0.3
	Max. Insertion Loss	dB	0.5
	Typ. Isolation	dB	35
	Min. Isolation	dB	30
Reflection Band	Wavelength Range	nm	1290-1330(830-870) 1530-1600(1270-1350)
	Typ. Insertion Loss	dB	0.3
	Max. Insertion Loss	dB	0.5
	Typ. Isolation	dB	15
	Min. Isolation	dB	12
Min. Return Loss		dB	35
Min. Directivity		dB	35
Max. TDL		dB	0.15
Package Dimensions		mm	Bare Fiber & Loose Tube $\Phi 5.5 \times 55$
			3mm Cable 12(W)*10(H)*120(L)
Max. Optical Power (CW)		mW	500
Max. Tensile Load		N	5
Fiber Type		um	Multimode Fiber 62.5/125/250 or 50/125/250
Operating Temperature		°C	-5 to +70
Storage Temperature		°C	-40 to +85

*Above specifications are for device without connector.

*For devices with connectors, IL will be 0.2dB higher and RL will be 20dB lower.

Package Dimensions

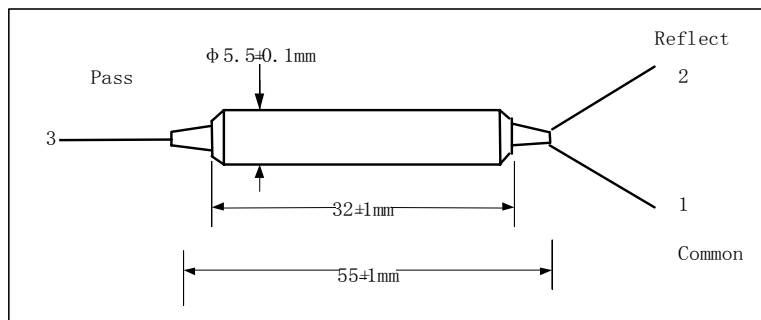

Ordering Information

AMMFWDM-①①①①-②-③③③-④④④-⑤

①①①①: Wavelength

3155 - 1310nm Pass / 1550nm Reflect
5531 - 1550nm Pass / 1310nm Reflect
8531 - 850nm Pass / 1310nm Reflect
3185 - 1310nm Pass / 850nm Reflect

③③③: Connector Type on Port 1, 2 & 3

1 - FC/UPC
2 - ST/UPC
3 - LC/UPC
4 - SC/UPC
N - None

④④④: Fiber Jacket on Port 1, 2 & 3

B - 250um Bare Fiber
L - 900um Loose Tube
C - 3mm Cable
S - Specify

②: Fiber Core Diameter

1 - 62.5um
2 - 50um

S - Specify

⑤: Fiber Length

1 - 1.0m
S - Specify